

- Compression load cell
 - 2000 divisions OIML R60 class C
 - Measuring element from Stainless Steel
 - Hermetically sealed, fully welded
 - Protected IP 68 (EN 60529) and IP 69K (ISO 20653)
 - Easy installation
 - Available in **ATEX** version (optional) Zone 0-1-2 (gas) and 20-21-22 (dust)
 - Application: Tanks and silos weighing systems with low profile requirement
- 压式称重传感器
 - 2000分度, OIML R60 C级
 - 不锈钢测量元件
 - 完全焊接密封
 - 防护等级 IP68 (EN 60529)和IP 69K (ISO 20653)
 - 简易安装
 - 防爆可选**ATEX** 0-1-2区(气体)和20-21-22(粉尘)
 - 应用: 适用于安装空间受限的料罐和料斗称重系统

Model 型号	Nominal capacity 量程 Ln	Accuracy class 精确度等级 n. OIML	Minimum division 最小分度值 vmin	Service load 安全过载 150 % Ln	Safe load limit 安全载荷极限 200 % Ln
420 2.5 t	2.5 t	2000	0.25 kg	3.75 t	5 t
420 5 t	5 t	2000	0.5 kg	7.5 t	10 t
420 10 t	10 t	2000	1 kg	15 t	20 t
420 20 t	20 t	2000	2 kg	30 t	40 t
420 30 t	30 t	2000	3 kg	45 t	60 t

MODEL 420

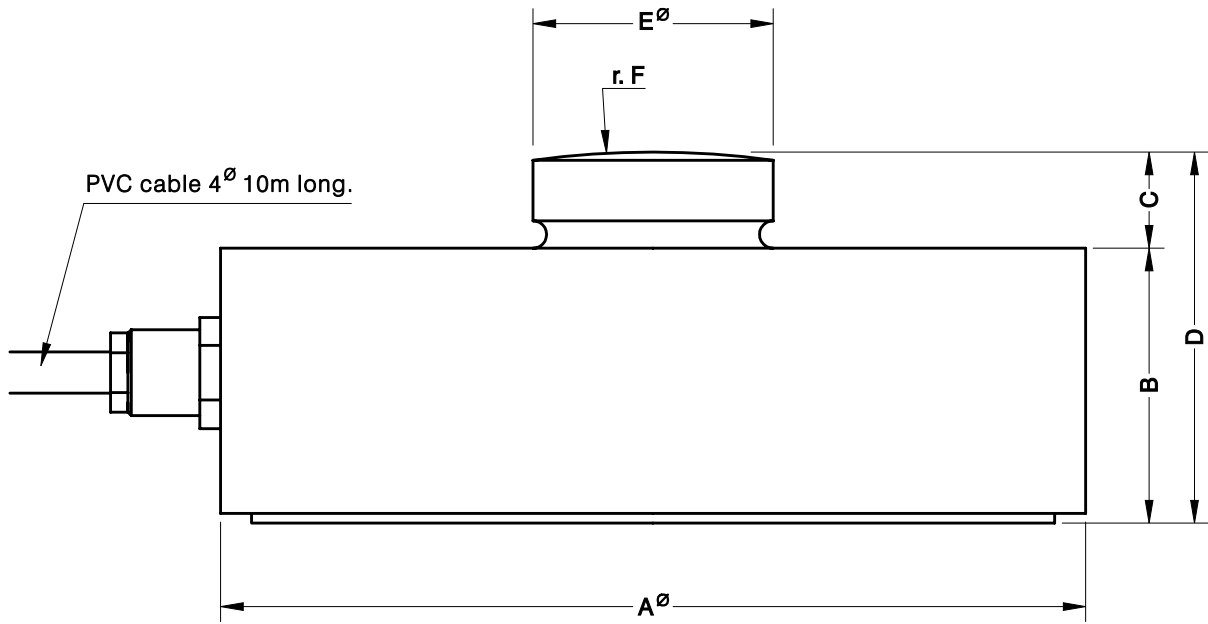

Nominal Load 量程	A \emptyset	B	C	D	E \emptyset	r. F	Transport Weight 重量
2.5...10 t	82	32	12	44	22	130	1.1 kg
20...30 t	126	40	14	54	35	200	2.8 kg

Dimensions in mm. 单位: mm.

SPECIFICATIONS			技术参数
Nominal capacities (Ln)	2.5-5-10-20-30	t	量程 (Ln)
Accuracy class	2000	n. OIML	精确度等级
Minimum dead load	0	%Ln	最小静载荷
Service load	150	%Ln	安全过载
Safe load limit	200	%Ln	安全载荷极限
Total error	< ± 0.025	%Sn	综合误差
Repeatability error	< ± 0.015	%Sn	重复性误差
Temperature effect:			温度影响:
on zero	< ± 0.01	%Sn/5 °C	零点
on sensitivity	< ± 0.009	%Sn/5 °C	灵敏度
Creep error (30 minutes)	< ± 0.024	%Sn	蠕变 (30分钟)
Temperature compensation	-10...+40	°C	温度补偿
Temperature limits	-50...+70	°C	温度极限
Nominal sensitivity (Sn)	2 \pm 0.1%	mV/V	灵敏度
Nominal input voltage	10	V	激励电压
Maximum input voltage	15	V	最大激励电压
Input impedance	800 \pm 30	Ω	输入阻抗
Output impedance	700 \pm 5	Ω	输出阻抗
No load output	± 2	%Sn	空荷输出
Insulation resistance	> 5000	M Ω	绝缘电阻
Maximum deflection (at Ln)	< 0.6	mm	最大形变量 (量程内)

ELECTRICAL CONNECTION 电气连接:

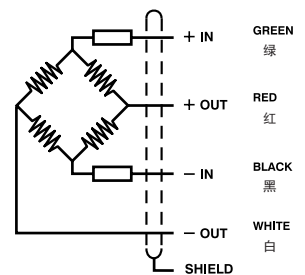

MOUNTING KIT LIFT-OFF PREVENTION FOR SILO FOR MOD.420

适用于料斗的带限位的安装附件MOD.420

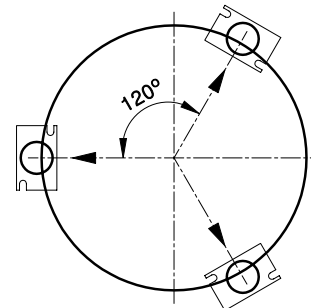
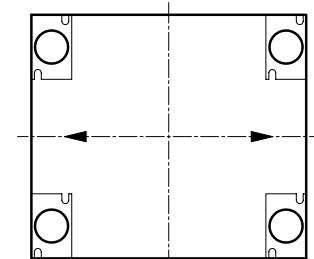
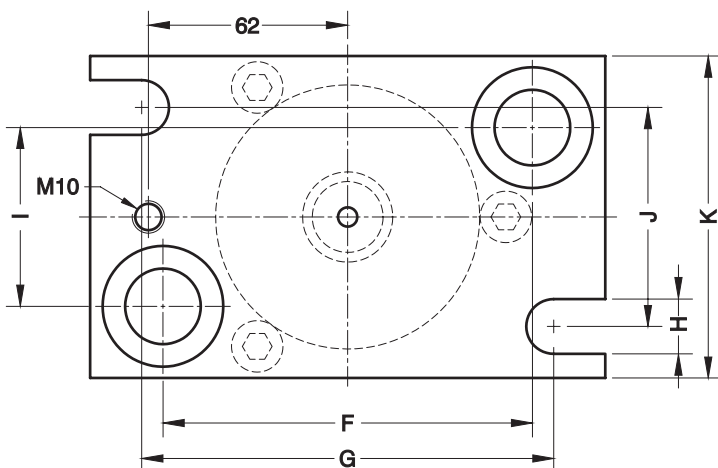
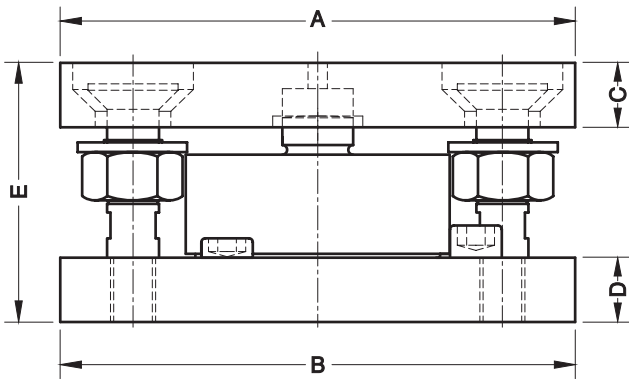

Accessory 附件	Nominal Load 量程	A	B	C	D	E	F	G	H	I	J	K	Transport weight 重量
42901	2.5-5-10 t	160	160	20	20	80	115	128	17	55.5	68	100	5.3 kg
42902	20-30 t	218	218	25	25	100	168	180	21	100	100	150	13.5 kg

	Alloy Steel zinc-plated / 合金钢镀锌		Stainless Steel / 不锈钢	
	42901	42902	42901i	42902i
Maximum horizontal offset 最大横向位移	±3 mm	±3 mm	±3 mm	±3 mm
Maximum lift-off force 最大倾翻力	72 kN	124 kN	72 kN	124 kN
Maximum horizontal force 最大横向力	22 kN	32 kN	22 kN	32 kN

Dimensiones en mm. 单位: mm.