

REPETIDOR DE PESO



- Repetidor de peso para SMART, MATRIX II y SWIFT.
- 7 dígitos de 57 mm altura para peso y 8 LEDS de estado. Alto brillo.
- Caja Acero inoxidable IP65.
- Comunicaciones RS-232 y RS-485.

- Alimentación externa:
230 ± 10% V AC 50/60 Hz 12W
- Soporte de anclaje y visera incluidos.

89316 Repetidor RD 60

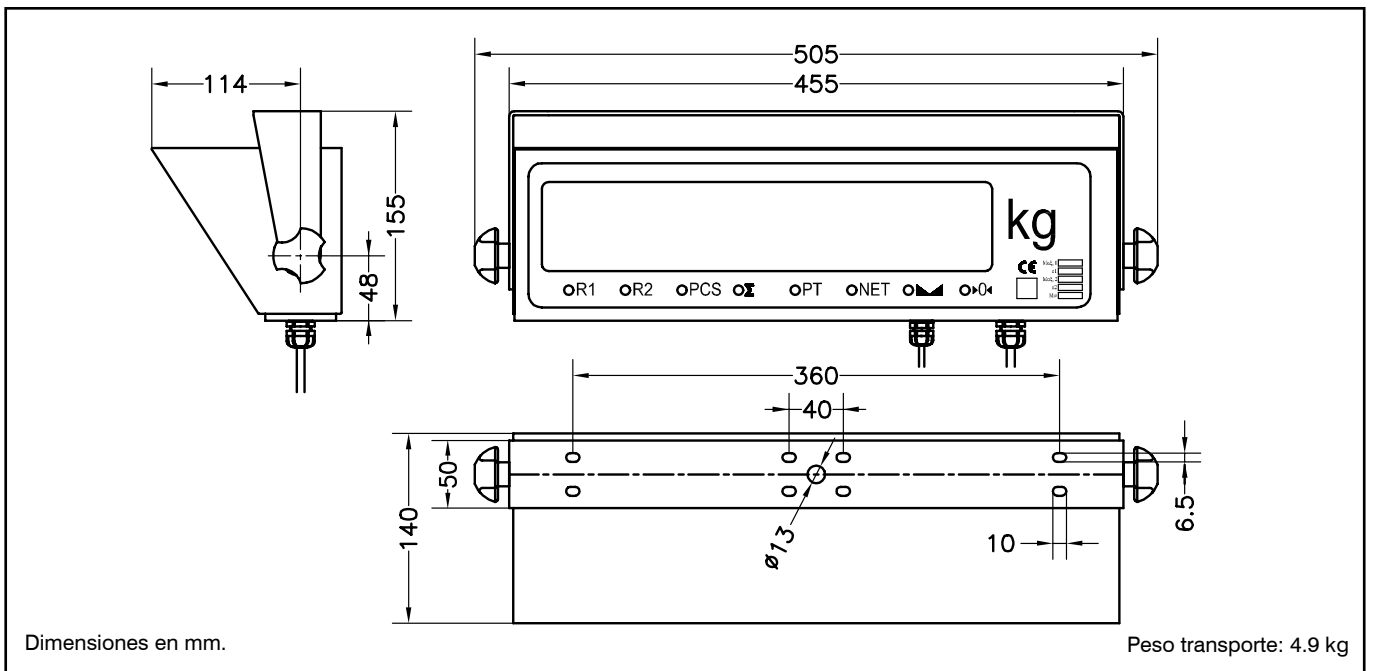

REMOTE DISPLAY FOR WEIGHING



- Remote display for SMART, MATRIX II and SWIFT
 - 7 digit weight LED 57 mm and 8 status LED. High bright.
 - Stainless Steel enclosure IP65.
 - Communication RS-232 and RS-485.
 - External Power supply: 230 ± 10% V AC 50/60 Hz 12W.
 - Mounting hardware included.
- 89316 Remote Display RD 60**

