

- Célula de carga de doble cizalladura
  - 3000 divisiones OIML R60 clase C
  - Soporte elástico de acero inoxidable
  - Sellado hermético, completamente soldada
  - Protección IP 68 (EN 60529) e IP69K (ISO 20653)
  - Fácil montaje
  - Disponible en versión **ATEX** (opcional)  
Zona 0-1-2 (gas) y 20-21-22 (polvo)
  - Kit de montaje disponible en versión certificada EN1090 (opcional)
  - Aplicaciones: Sistemas de pesaje de tanques y silos con requerimientos de alta linealidad y bajo perfil
- Double shear load cell
  - 3000 divisions OIML R60 class C
  - Measuring element from Stainless Steel
  - Hermetically sealed, fully welded
  - Protected IP 68 (EN 60529) and IP69K (ISO 20653)
  - Easy installation
  - Available in **ATEX** version (optional)  
Zone 0-1-2 (gas) and 20-21-22 (dust)
  - Mounting Kit available in version certified according EN1090 (optional)
  - Application: Tanks and silos weighing systems with highly linear and low profile requirements

Modelo Model	Carga nominal Nominal capacity Ln	Clase de precisión Accuracy class n. OIML	División mínima Minimum division vmin	Carga de servicio Service load 150 % Ln	Carga límite Safe load limit 200 % Ln
460 5 t	5 t	3000	0.5 kg	7.5 t	10 t
460 10 t	10 t	3000	1 kg	15 t	20 t
460 20 t	20 t	3000	2 kg	30 t	40 t
460 30 t	30 t	3000	3 kg	45 t	60 t
460 50 t	50 t	3000	5 kg	75 t	100 t
460 75 t	75 t	3000	7.5 kg	112.5 t	150 t
460 100 t	100 t	3000	10 kg	150 t	200 t

# MODELO 460

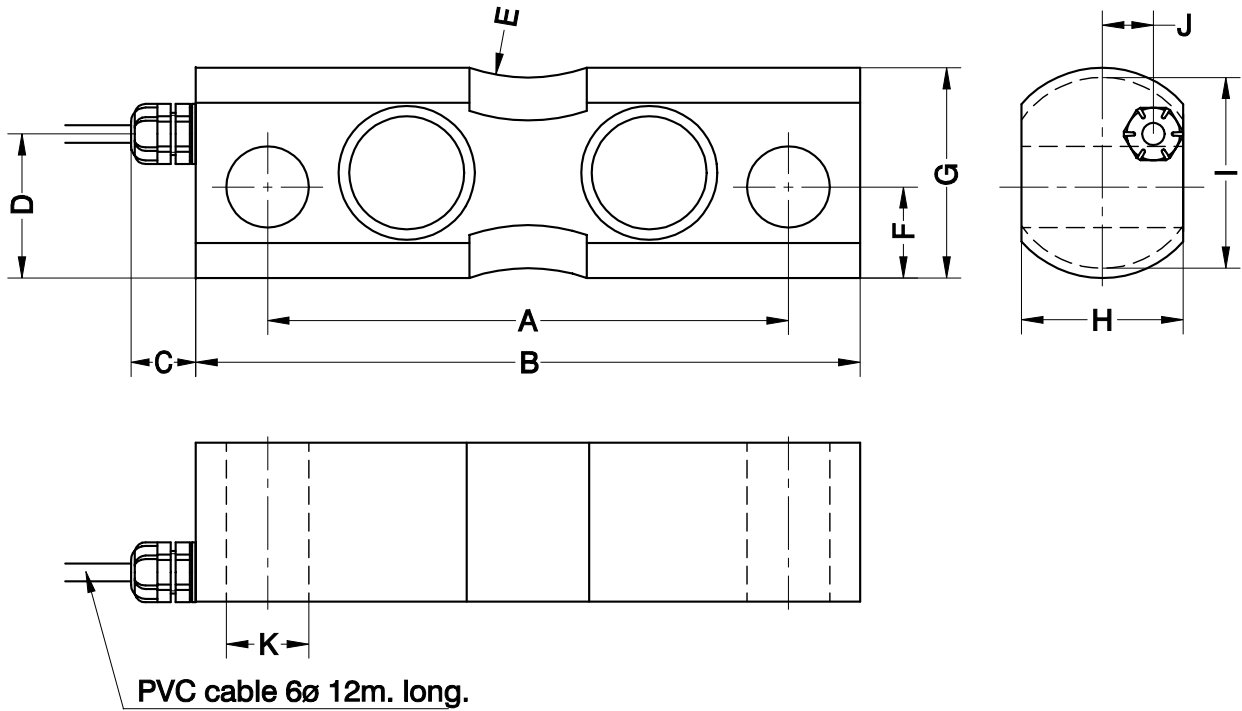

Carga Nominal Load	A	B	C	D	E	F	G∅	H	I∅	J	K∅	Peso transporte Transport Weight
5...20 t	145	185	16	41	r.50	25.7	59.5	45	55	14	23	3.2 kg
30...50 t	220	285	16	48	r.50	29.7	74.5	60	66	22	30	8.6 kg
75...100 t	260	340	16	66	r.50	37.2	99.5	80	91	32	50	16.2 kg

Dimensiones en mm. Dimensions in mm.

ESPECIFICACIONES			SPECIFICATIONS
Cargas nominales (Ln)	5-10-20-30 50-75-100	t	Nominal capacities (Ln)
Clase de precisión	3000	n. OIML	Accuracy class
Carga mínima	0	%Ln	Minimum dead load
Carga de servicio	150	%Ln	Service load
Cargas límite	200	%Ln	Safe load limit
Error combinado	< ±0.017	%Sn	Total error
Error repetibilidad	< ±0.015	%Sn	Repeatability error
Efecto de la temperatura: en el cero	< ±0.01	%Sn/5 °C	Temperature effect: on zero
en la sensibilidad	< ±0.006	%Sn/5 °C	on sensitivity
Error de fluencia (30 minutos)	< ±0.016	%Sn	Creep error (30 minutes)
Compensación de temperatura	-10...+40	°C	Temperature compensation
Límites de temperatura	-30...+70	°C	Temperature limits
Sensibilidad nominal (Sn)	2 ±0.1%	mV/V	Nominal sensitivity (Sn)
Tensión de alimentación nominal	10	V	Nominal input voltage
Tensión de alimentación máxima	15	V	Maximum input voltage
Resistencia de entrada	800 ±30	Ω	Input impedance
Resistencia de salida	700 ±5	Ω	Output impedance
Desequilibrio inicial	±2	%Sn	No load output
Resistencia de aislamiento	> 5000	MΩ	Insulation resistance
Deformación máxima (a Ln)	0.6-1	mm	Maximum deflection (at Ln)

### CONEXIÓN ELÉCTRICA ELECTRICAL CONNECTION:

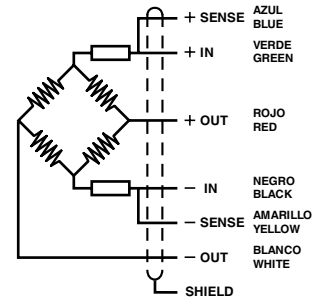

«SENSES»: 2 hilos adicionales, para mantener constante la alimentación en la célula, con una instrumentación adecuada. Utilizar especialmente para cables largos y amplio margen de temperatura.  
PANTALLA: No conectada al cuerpo del transductor.

«SENSES»: 2 additional wires to maintain a constant voltage supply at the load cell when used with proper instrumentation. Use specially when long wires and wide temperature range.  
SHIELD: Not connected to transducer body.

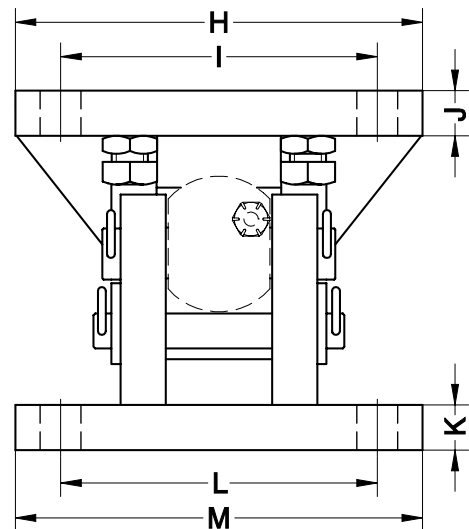
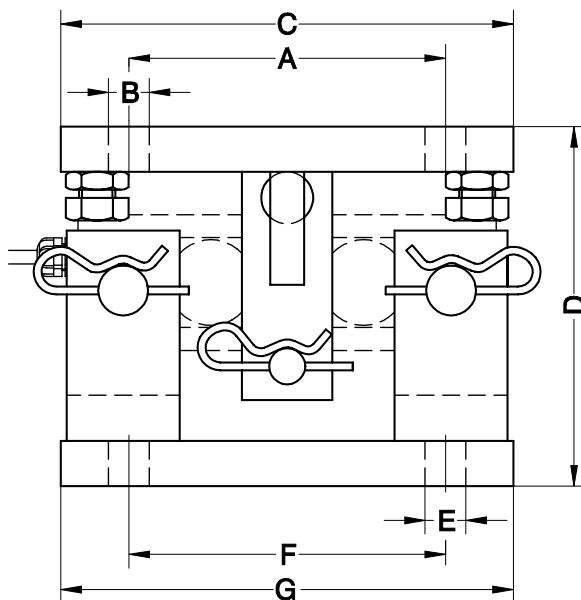
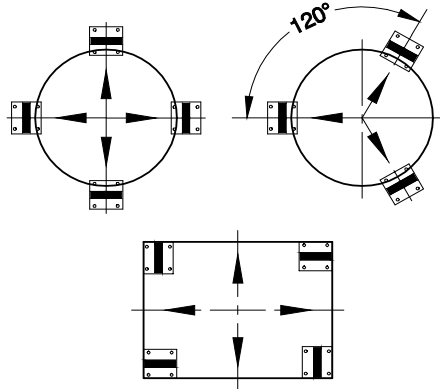
**SOPORTE COMPLETO SILO CON ANTI-VUELCO PARA M.460**  
**MOUNTING KIT LIFT-OFF PREVENTION FOR SILO FOR M460**

Accesorio Accessory	Carga Nominal Load	A	B $\emptyset$	C	D	E $\emptyset$	F	G	H	I	J	K	L	M	Peso Transport Weight
<b>46901</b>	5...20 t	140	18	200	160	18	140	200	180	140	20	20	140	180	17 kg
<b>46902</b>	30...50 t	175	22	300	200	22	175	300	220	175	25	25	175	220	39 kg
<b>46903</b>	75...100 t	220	26	370	270	26	220	370	300	220	30	30	220	300	82 kg

	Acero cincado / Alloy Steel zinc-plated			Acero inoxidable / Stainless Steel		
	<b>46901</b>	<b>46902</b>	<b>46903</b>	<b>46901i</b>	<b>46902i</b>	<b>46903i</b>
Máximo desplazamiento transversal a la célula <i>Maximum offset transverse to load cell</i>	±5 mm	±5 mm	±10 mm	±5 mm	±5 mm	±10 mm
Máxima fuerza de levantamiento <i>Maximum lift-off force</i>	62.7 kN	101 kN	206.9 kN	78.4 kN	127.5 kN	228.5 kN
Máxima fuerza transversal a la célula de carga <i>Maximum force transverse to load cell</i>	41.2 kN	68.6 kN	116.7 kN	35.3 kN	52.9 kN	107.8 kN
Máxima fuerza longitudinal a la célula de carga <i>Maximum force longitudinal to load cell</i>	92.2 kN	143.2 kN	151 kN	70.6 kN	141.2 kN	180.4 kN

 Dimensiones en mm. *Dimensions in mm.*

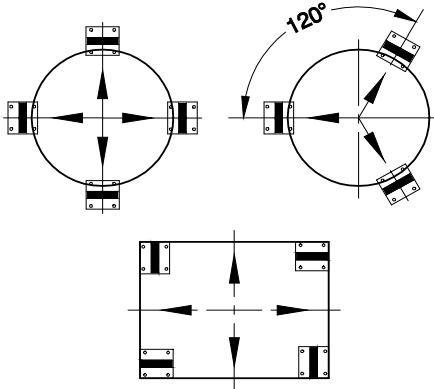
**SOPORTE COMPLETO SILO CON ANTI-VUELCO PARA M.460 (50-100t)  
 MOUNTING KIT LIFT-OFF PREVENTION FOR SILO FOR M460 (50-100t)**

Certificado según EN 1090. Marcado CE según el Reglamento Europeo de Productos de la Construcción (CPR).  
 Certified according to EN 1090. CE Marked under Construction Product Regulation (CPR).

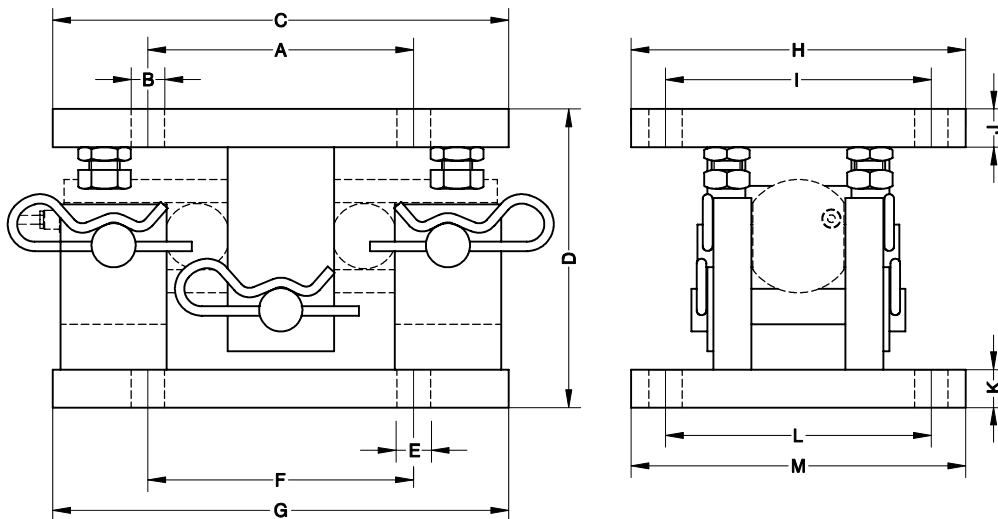

Accesorio Accessory	Carga Nominal Load	A	B Ø	C	D	E Ø	F	G	H	I	J	K	L	M	Peso Transport Weight
<b>46902CG</b>	50 t	175	22	300	197	22	175	300	220	175	25	25	175	220	39 kg
<b>46903CG</b>	100 t	220	26	370	256	26	220	370	300	220	30	30	220	300	82 kg

	Acero galvanizado / Alloy Steel Galvanized	
	<b>46902CG</b>	<b>46903CG</b>
Máximo desplazamiento transversal a la célula <i>Maximum offset transverse to load cell</i>	±5 mm	±10 mm
Máxima fuerza de levantamiento <i>Maximum lift-off force</i>	124 kN	250 kN
Máxima fuerza transversal a la célula de carga <i>Maximum force transverse to load cell</i>	75 kN	95 kN
Máxima fuerza longitudinal a la célula de carga <i>Maximum force longitudinal to load cell</i>	152 kN	195 kN
Máxima fuerza de carga vertical <i>Maximum vertical load force</i>	1200 kN	2530 kN

Dimensiones en mm.  
 Dimensions in mm.