

# CONNECTION

The connection system for each load cell is the one showed on the figure below:

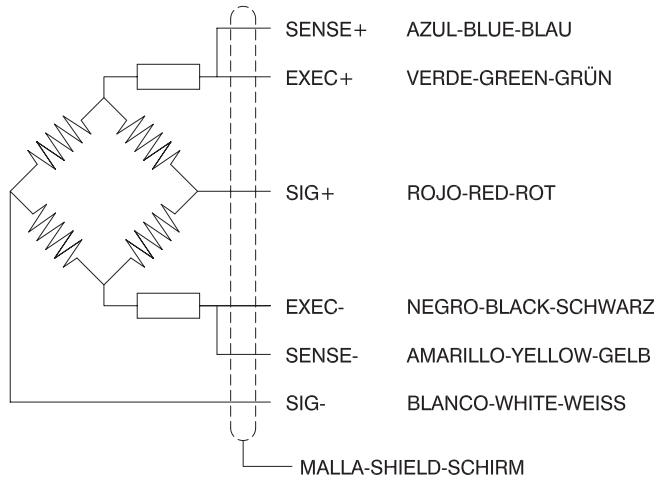

Figure 1

The colour code showed corresponds with UTILCELL’s load cells

That connection system is marked on the junction box board. It is a six wire system, so, in case of using load cells with four wire system it will be necessary to bridge Sense+ with Exec+ and Sense- with Exec-. A maximum of 8 load cells can be connected to the board (LC1 to LC8), as the figure below shows:

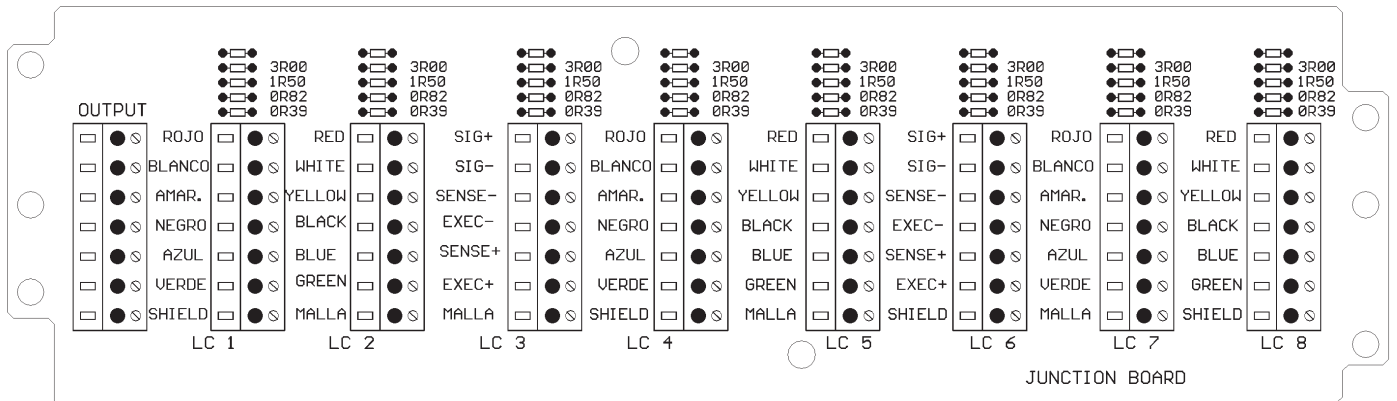

Figure 2

The cable with the output signal to the weight indicator comes out of the OUTPUT terminal block.

# CORNER ADJUSTMENT FOR MODEL 740

The corner adjustment system is based on a series of resistors of different values which lower the output signal provided by the load cell as necessary.

To achieve it each one of these resistors is connected in parallel with a 0 Ω resistor which void it. If this 0 Ω resistor is taken out then its associated resistor is activated, lowering the load cell output signal.

The diagram is the showed in the figure below:

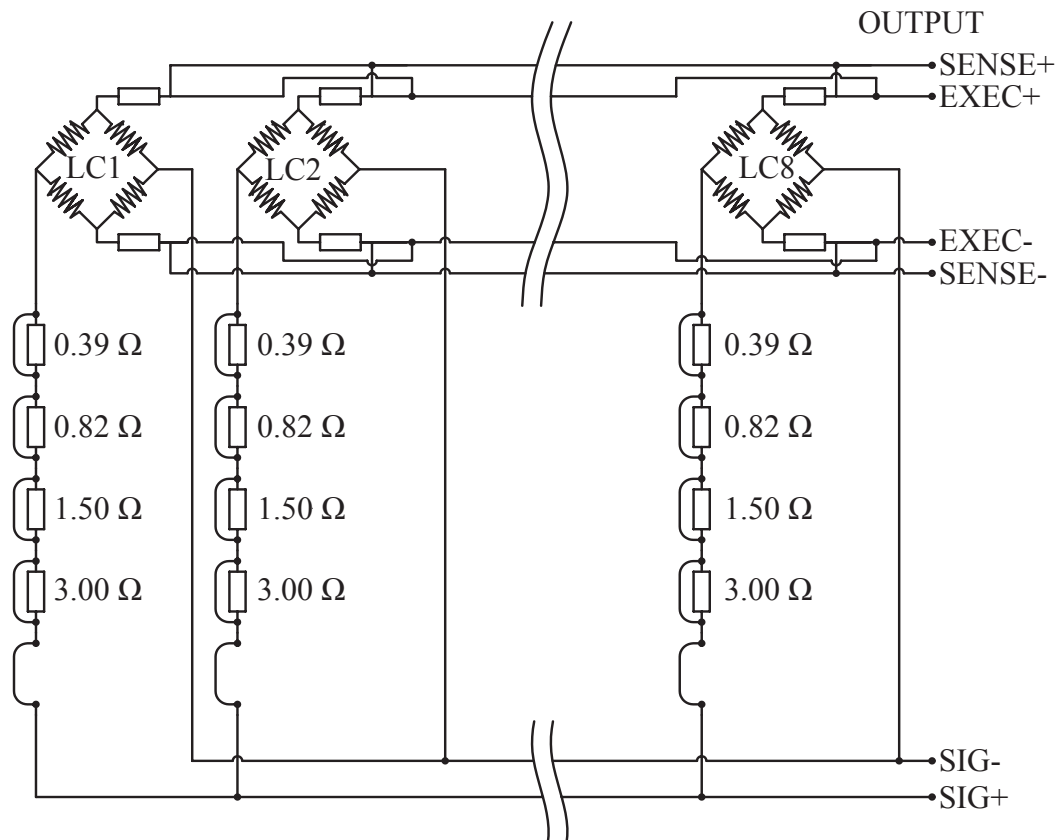

Figure 3

The system to determine which resistors have to be activated is the following:

- We apply a test load, as closer as possible to each of the load cells of the platform.
- We write down the weight showed by the indicator for each one of the load cells.
- We calculate the difference of weight among each one of the load cells and the one which has given the lowest weight (no resistor will be activated for that load cell).
- We look for the value of that difference of weight in the following table, according the test load, for each load cell and we cut the 0 Ω resistor associated to the resistor/s to be activated.

	Test load			Necessary resistance [Ω]	Resistors to be activated (✕)			
	8000 kg	10000 kg	12000 kg		0.39 Ω	0.82 Ω	1.50 Ω	3.00 Ω
Corner error (difference among the affected load cell and the one which has given the lowest weight value) [kg]	0.0	0.0	0.0	0.0	—	—	—	—
	2.2	2.8	3.3	0.39	✕	—	—	—
	6.9	8.6	10.3	0.82	—	✕	—	—
	11.5	14.4	17.3	1.21	✕	✕	—	—
	15.4	19.3	23.1	1.50	—	—	✕	—
	19.3	24.1	28.9	1.89	✕	—	✕	—
	23.9	29.9	35.9	2.32	—	✕	✕	—
	28.6	35.7	42.8	2.71	✕	✕	✕	—
	32.4	40.5	48.6	3.00	—	—	—	✕
	36.2	45.3	54.4	3.39	✕	—	—	✕
	40.9	51.1	61.3	3.82	—	✕	—	✕
	45.5	56.9	68.2	4.21	✕	✕	—	✕
	49.3	61.7	74.0	4.50	—	—	✕	✕
	53.1	66.4	79.7	4.89	✕	—	✕	✕
	57.8	72.2	86.6	5.32	—	✕	✕	✕
	62.4	77.9	93.5	5.71	✕	✕	✕	✕