



LIFT-OFF PREVENTION SYSTEMS

Acc. 30907 (5...500kg)

BASIC MOUNTING INSTRUCTIONS

(Rev. 1 – 03/13)



1. MATERIAL RECEIVED WITH THE MOUNTING KIT



Figure 1

2. NECESSARY TOOLS TO PERFORM THE MOUNTING

- SPANNER OF 19mm.
- ALLEN WRENCH OF 6mm.



Figure 2

3. PLACE THE ACCESSORY IN ITS INSTALLATION POSITION AND FIX IT TO THE FOUNDATION AND TO THE LEG OF THE TANK



Figure 3

4. PLACE THE UPPER CUP ON THE UPPER PLATE



Figure 4

5. PERFORM THE JOINT MOUNTING KIT INTO THE LOAD CELL



Figure 5



Figure 6

6. INSERT THE LOAD CELL IN THE MOUNTING ACCESSORY, IT IS FIXED TO THE FOUNDATION AND TO THE TANKS LEG. KEEP IN MIND THE DIRECTION OF THE LOAD ARROW IN THE LOAD CELL



Figure 7

7. FIX THE LOAD CELL TO THE MOUNTING ACCESSORY, SCREWING THE NUTS. ENSURE THAT THE LOAD CELL IS CENTERED AND STRAIGHT.

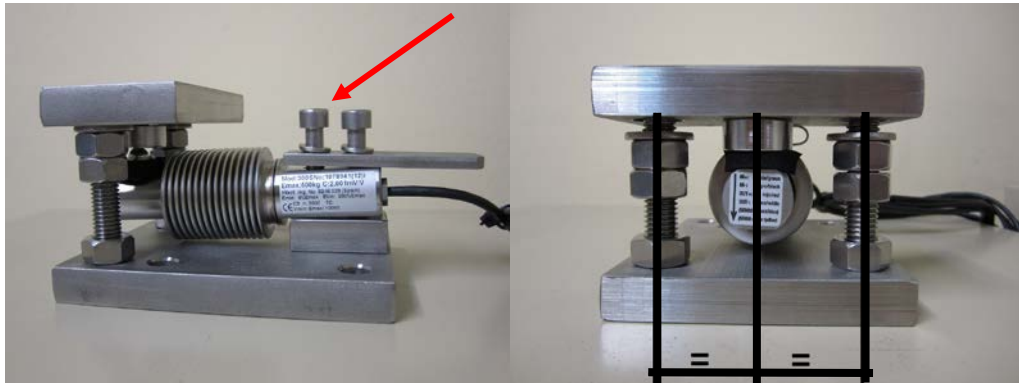

Figure 8

8. ONCE THE LOAD CELL IS FIXED TO THE ACCESSORY, UNSCREW THE TWO LATERAL NUTS UNTIL THE TOP PLATE CONTACTS THE LOAD CELL

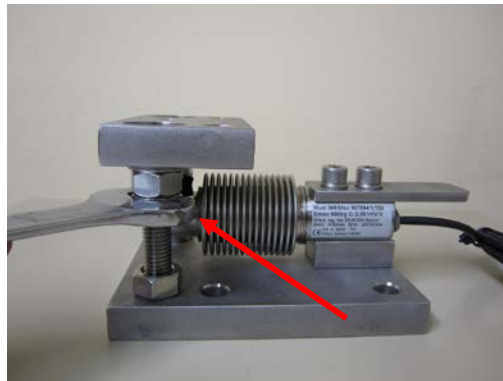

Figure 9

9. LEAVE A CLEARANCE BETWEEN TOP PLATE AND WASHER (2-3mm.)

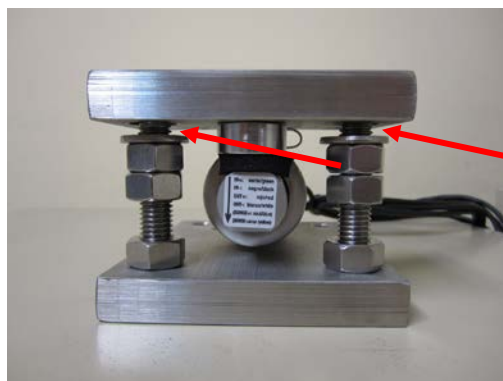

Figure 10

10. ENSURE THE PARALLELISM BETWEEN THE UPPER AND LOWER PLATE, D1 SHOULD BE EQUAL TO D2 AND D3 IN ALL THE CORNERS, ONCE THE ACCESSORY HAS FREE MOVEMENT

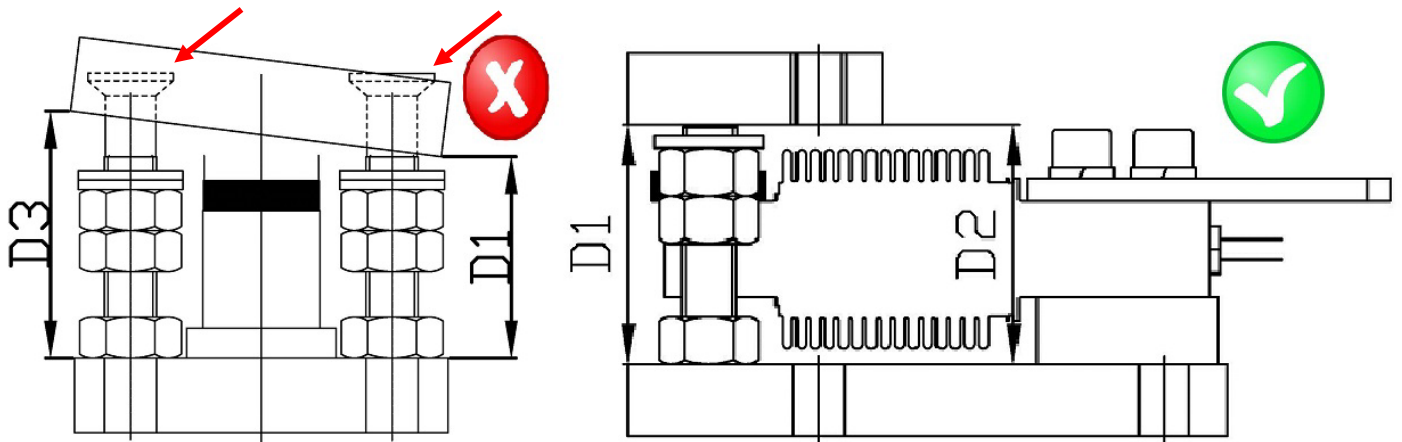

Figure 11

11. IF THERE IS A DEVIATION BETWEEN D1, D2 AND D3, THEN WE SHOULD PLACE METAL SHIMS OF DIFFERENT WIDTH (1,2 or 3mm) BETWEEN THE LEG OF THE TANK AND THE UPPER PLATE TO GET THE NECESSARY PARALLELISM FOR A CORRECT INSTALLATION (Figure 12)

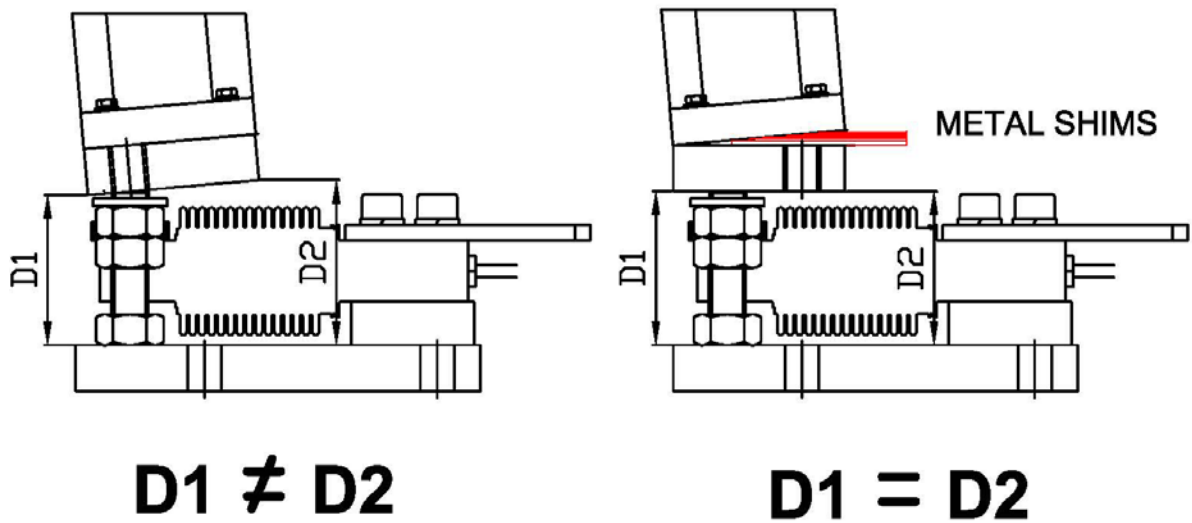

Figure 12

*perform the same procedure for D1 and D3, if necessary

12. ENSURE THAT THERE IS NO DEVIATION BY TORQUE BETWEEN UPPER AND LOWER PLATE

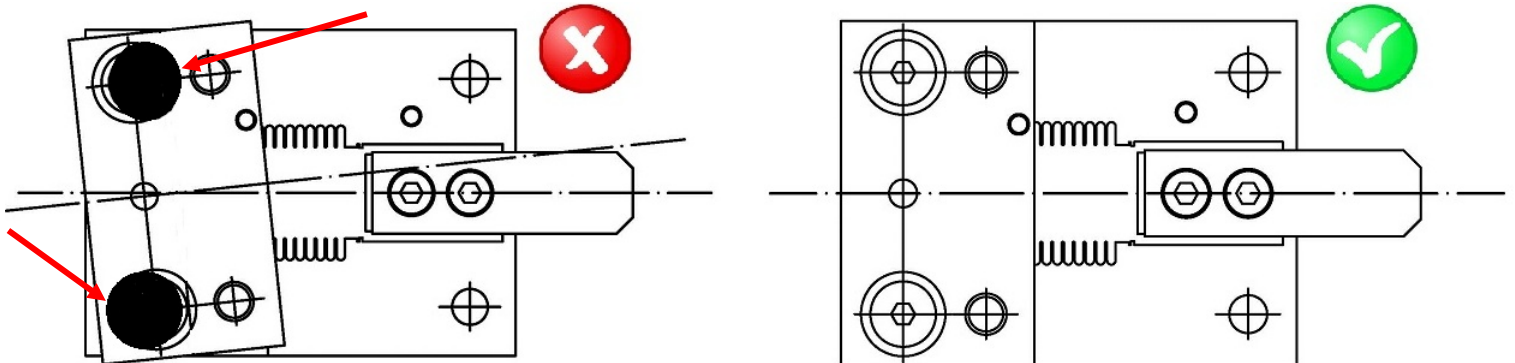

Figure 13