

EXAMPLE OF DOSING BY DISCHARGE AT TWO SPEEDS WITH SWIFT

Once are configured all the basic parameters of the device (SCALE DEF, OPTIONS, MASS CALIB. or mV CALIB.), we will configure the DIGITAL OUTPUTS menu, where we set the setpoint for the dosing. Afterwards we will configure the DIGITAL INPUTS menu where we will define the start and the end of the dosing.



Starting from the following example of dosing:

We have a tank of 500 kg of total weight with two load cells of 300 kg of capacity and we want to perform a 500 kg scale with a 200 g division.

We will make 5, 10, 15, 20 or 25 kg pots.

The SCALE DEF menu will be configured as follows:

CAP: 500 kg (Maximum capacity of the scale)

D1: 20 (Value of the scale division)

DP: 0,20 (Decimal point position)

0-TRACK: 0,5d (Zero follower band)

0-TOP: 1,9 (Allowed limit to the $\times 0 \times$ key)

0-START: OFF (Auto zeroes when it is turned on)

UNDERL: -20d (Lower range equal -20 divisions)

UNIT: kg (Units)

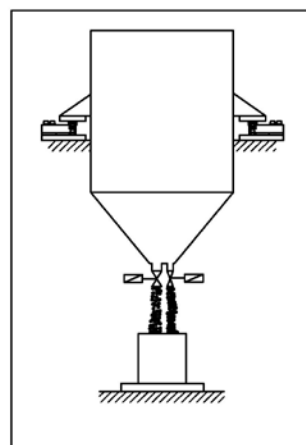





VALUES THAT WE SHOULD SET IN D_OUTs TO PERFORM THE DOSING BY DISCHARGE AT TWO SPEEDS ACCORDING TO THE EXAMPLE (5 kg pot)

D_OUT n	1	2	3
UL	-5,00	0,00	2,00
TYPE	NET	N_REL	P_REL
REL	1	1	1
TRIP	L	H	L
BD	0,00	0,00	0,00
HY	0,40	0,00	0,00
D.LOC	OFF	ON	OFF
HOLD	0,0	0,0	0,0
DELAY	0,0	0,0	0,0

Activating the TARE \rightarrow starts the coarse feeding from 0 to -3 kg. The last 2 kg discharge at fine feed. When reaching -5 kg, the discharge stops.

D_OUT's CONFIGURATION MENU

Press  +  (first press EXIT and hold and press →0←) the device will ask us for the PIN code, to configure this menu is not necessary because we will not change protected parameters, press  and get into the configuration menu, then press 5 times  key, now we are in **D_OUT** menu.

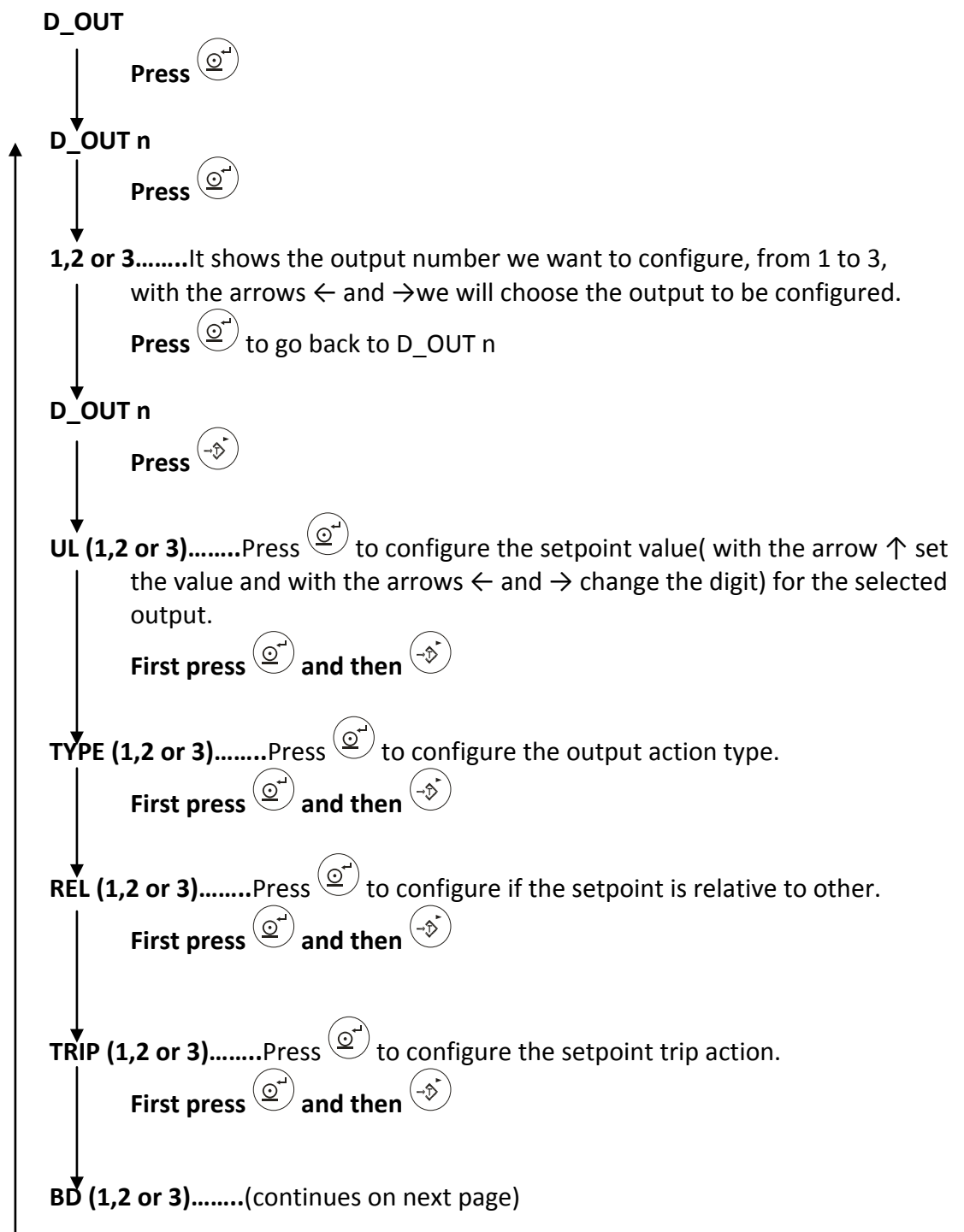

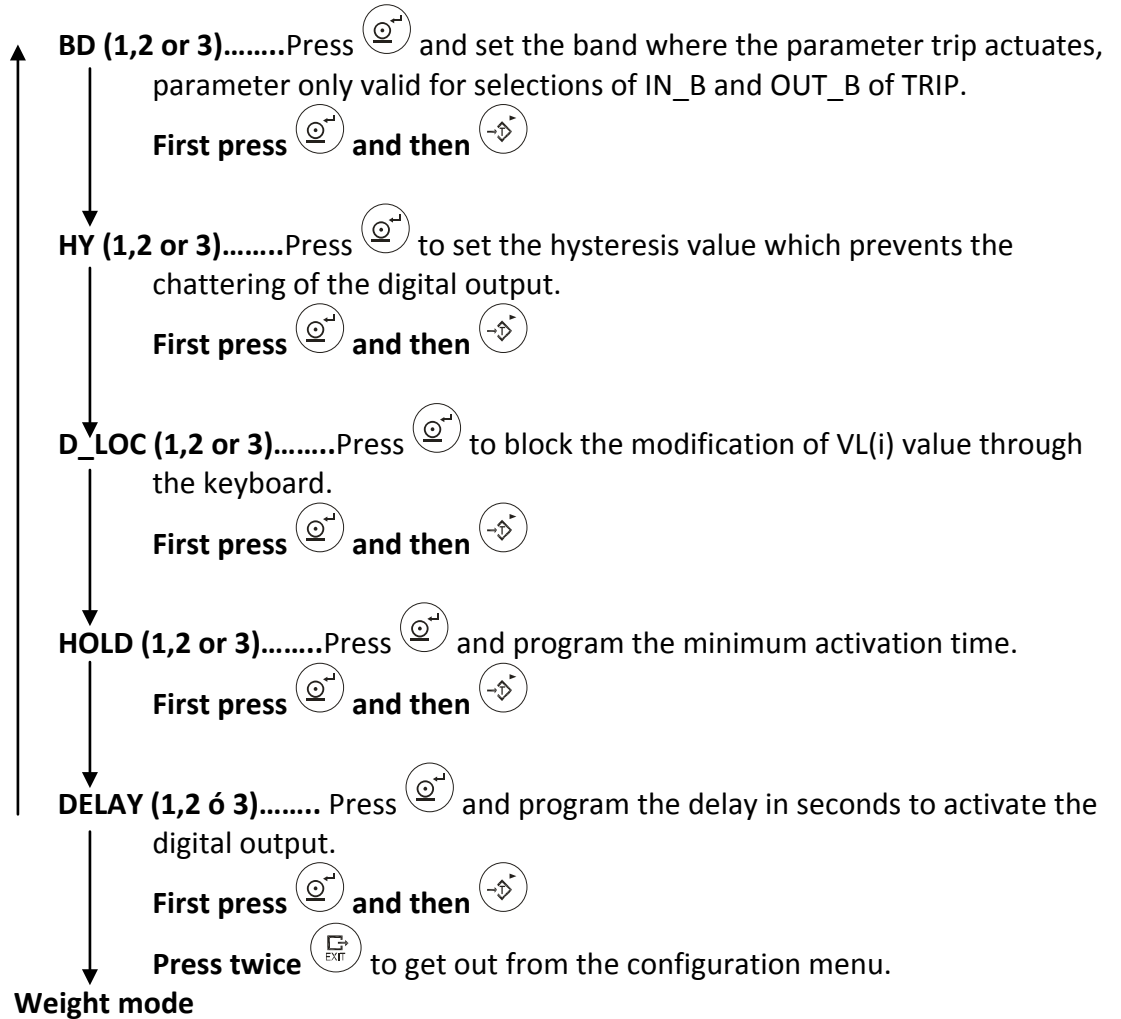





IMPORTANT: We should keep in mind that surely we will have to change the setpoint value, I mean, we have to set a lower value because of the gap between the closing of the relay, the in flight material and the weight of the scale.

Now to finish we should set the digital input menu, where we will frame the dosage maneuver.

VALUES THAT WE SHOULD SET IN THE D_IN (Digital Inputs) TO PERFORM THE DOSING AT TWO SPEEDS ACCORDING TO THE EXAMPLE

D_IN n	1	2
TYPE	TARE	C.TARE
FUNC	H	H

D_IN's CONFIGURATION MENU

Press  +  (first EXIT and hold and then press →0←) the device will ask us for the PIN code, to set that menu is not necessary to introduce the PIN code, because we are not going to change any protected parameter, press  and go into the configuration menu, press  6 times and now we are in **D_IN** menu.

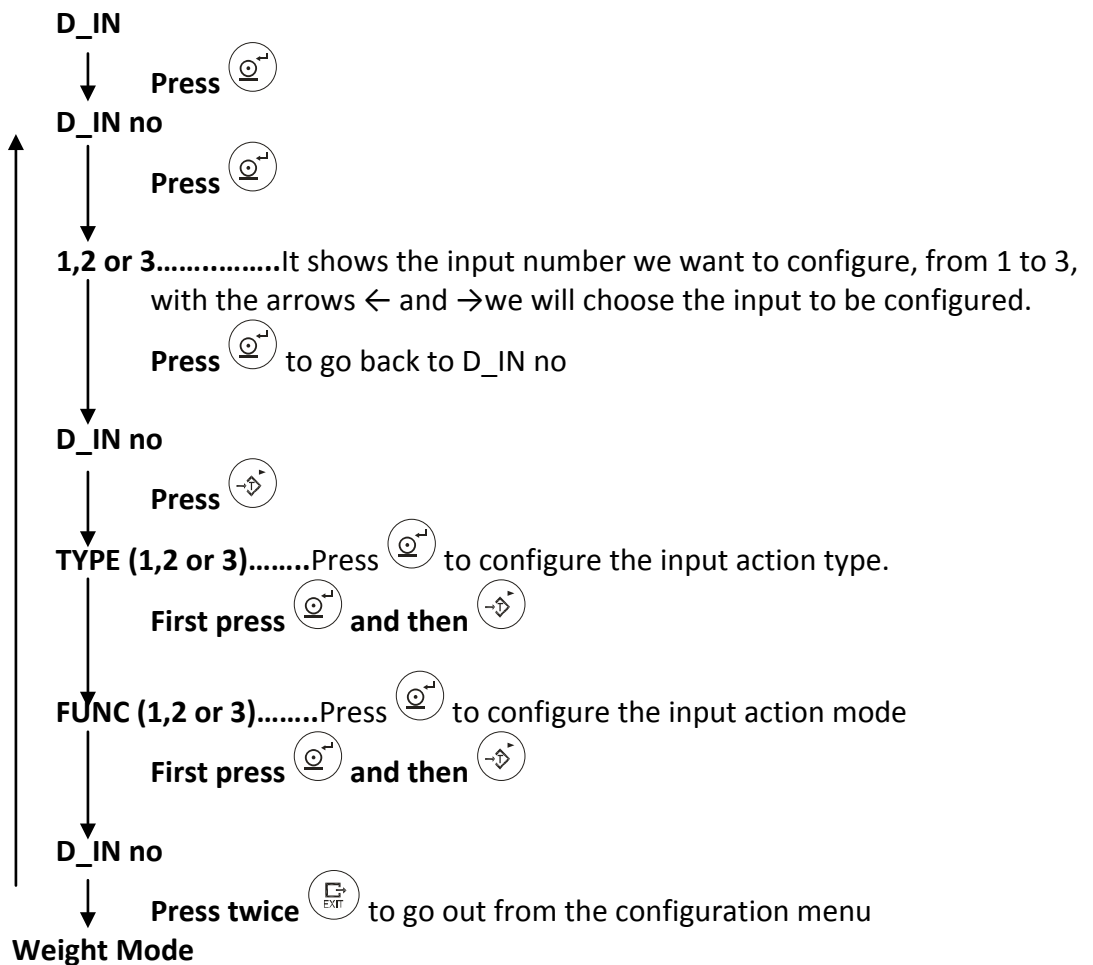

Once are configured the D_OUT and the D_IN, we should perform the following wiring:

The D_OUT 2 will be used to end the maneuver, I mean, we will connect the D_OUT 2 output to the D_IN 2 input, in this way, we will frame the maneuver. When the device will reach the setpoint, it will perform a C.TARE (Clear Tara) automatically to finish the maneuver.