

EXAMPLE OF DOSING BY CHARGE AT TWO SPEEDS WITH SMART

Once are configured all the basic parameters of the device (SCALE DEF, OPTIONS, MASS CALIB. or mV CALIB.), we will configure the DIGITAL OUTPUTS menu, where we set the setpoint for the dosing. Afterwards we will configure the DIGITAL INPUTS menu where we will define the start and the end of the dosing.



Finally we will show the connection ways for the SMART digital inputs and outputs, via SUB-D 25 connector or via cable glands for the SMART IP-65 version.

Starting from the following example of dosing:

We have got a 50kg load cell capacity and we want to perform a 30kg scale with a 10gr division.

We will make 5, 10, 15, 20 or 25kg pots.

The SCALE DEF menu will be configured as follows:

FUNCT: INDICA

BIRANGE: OFF (Multirange deactivated)

CAP: 30 Kg (Maximum capacity of the scale)

D1: 1 (Value of the scale division)

DP: 0,01 (Decimal point position)

0-TRACK: 0,5d (Zero follower band)

0-TOP: 1,9 (Allowed limit to the  key)

0-START: OFF (Auto zeroes when it is turned on)





0-NEG: OFF (Auto zeroes if negative weight)

UNIT: Kg (Units)

VALUES THAT WE SHOULD SET IN D_OUTs TO PERFORM THE DOSING BY CHARGE AT TWO SPEEDS ACCORDING TO THE EXAMPLE (5kg pot)

D_OUT n	1	2	3	4
UL	0	5,0	0	2,0
TYPE	NET	P_REL	P_REL	N_REL
REL	1	1	2	2
TRIP	H	H	L	H
BD	0	0	0	0
HY	0	0,02	0	0
D.LOC	ON	OFF	ON	OFF
OUTPUT	OFF	2	3	4

D_OUT's CONFIGURATION MENU

Press  +  (first press EXIT and hold and press →0←) the device will ask us for the PIN code, to configure this menu is not necessary because we will not change protected parameters, press  and get into the configuration menu, then press 5 times  key, now we are in **D_OUT** menu.

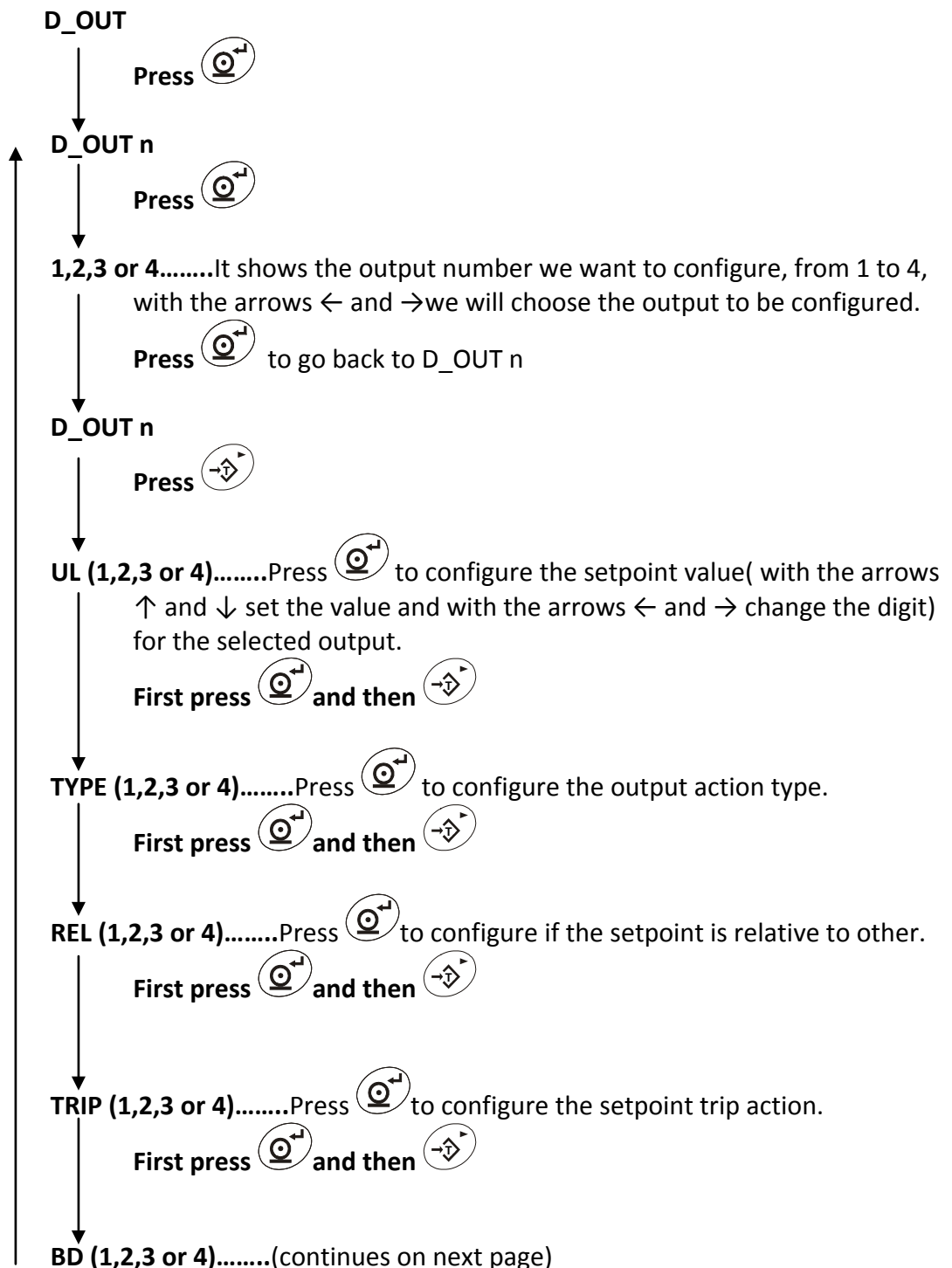

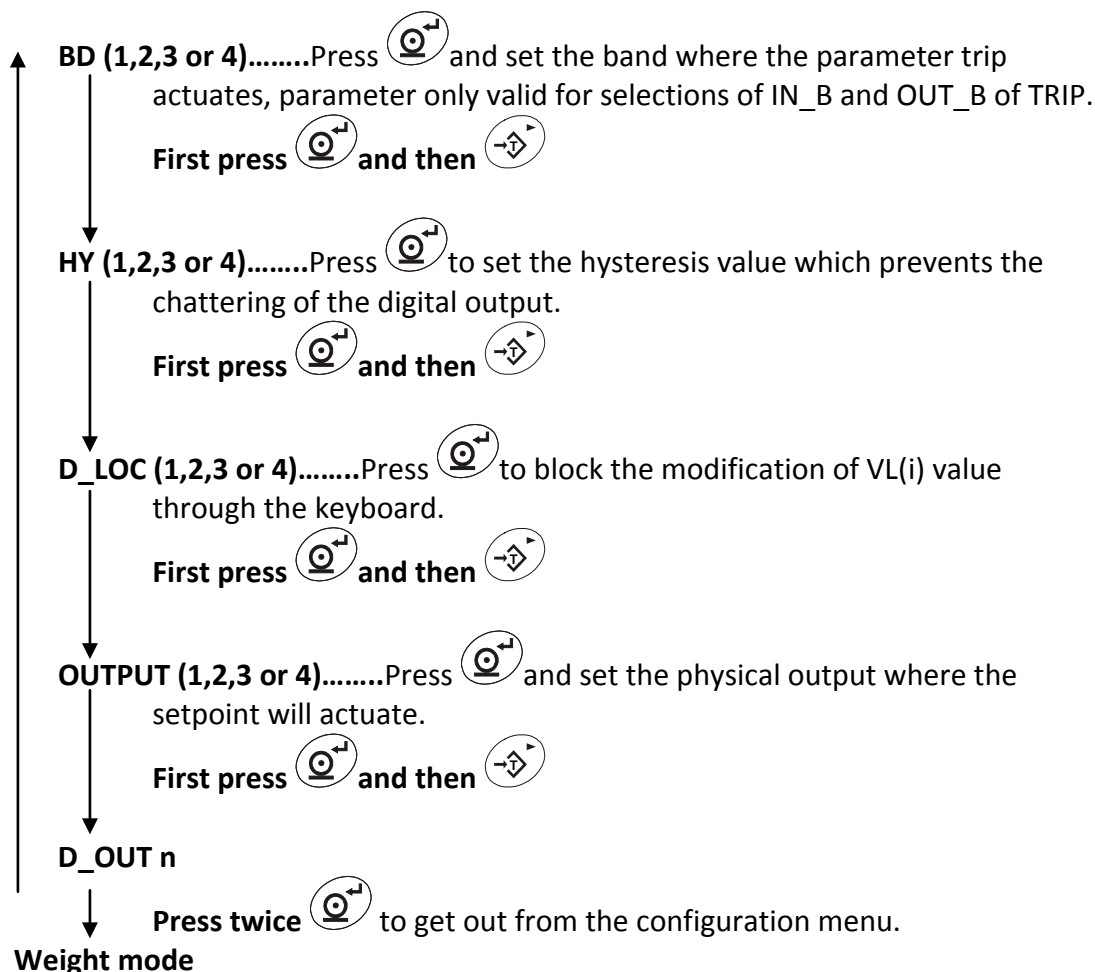

IMPORTANT: We should keep in mind that surely we will have to change the setpoint value, I mean, we have to set a lower value because of the gap between the closing of the relay, the in flight material and the weight of the scale.

NOTE: The dosing starts by activating the TARE function, NET weight, for this reason is necessary to put a tare or a container on the scale.





In case of not having a tare is necessary to consider performing the calibration of the scale without the top platform. In this way the scale will always give us a positive weight equal to the value of the platform.

Now to finish we should set the digital input menu, where we will frame the dosage maneuver.

VALUES THAT WE SHOULD SET IN THE D_IN (Digital Inputs) TO PERFORM THE DOSING AT TWO SPEEDS ACCORDING TO THE EXAMPLE

D_IN n	1	2
TYPE	TARE	C.TARE
FUNC	H	H

D_IN's CONFIGURATION MENU

Press  +  (first EXIT and hold and then press →0←) the device will ask us for the PIN code, to set that menu is not necessary to introduce the PIN code, because we are not going to change any protected parameter, press  and go into the configuration menu, press  6 times and now we are in **D_IN** menu.

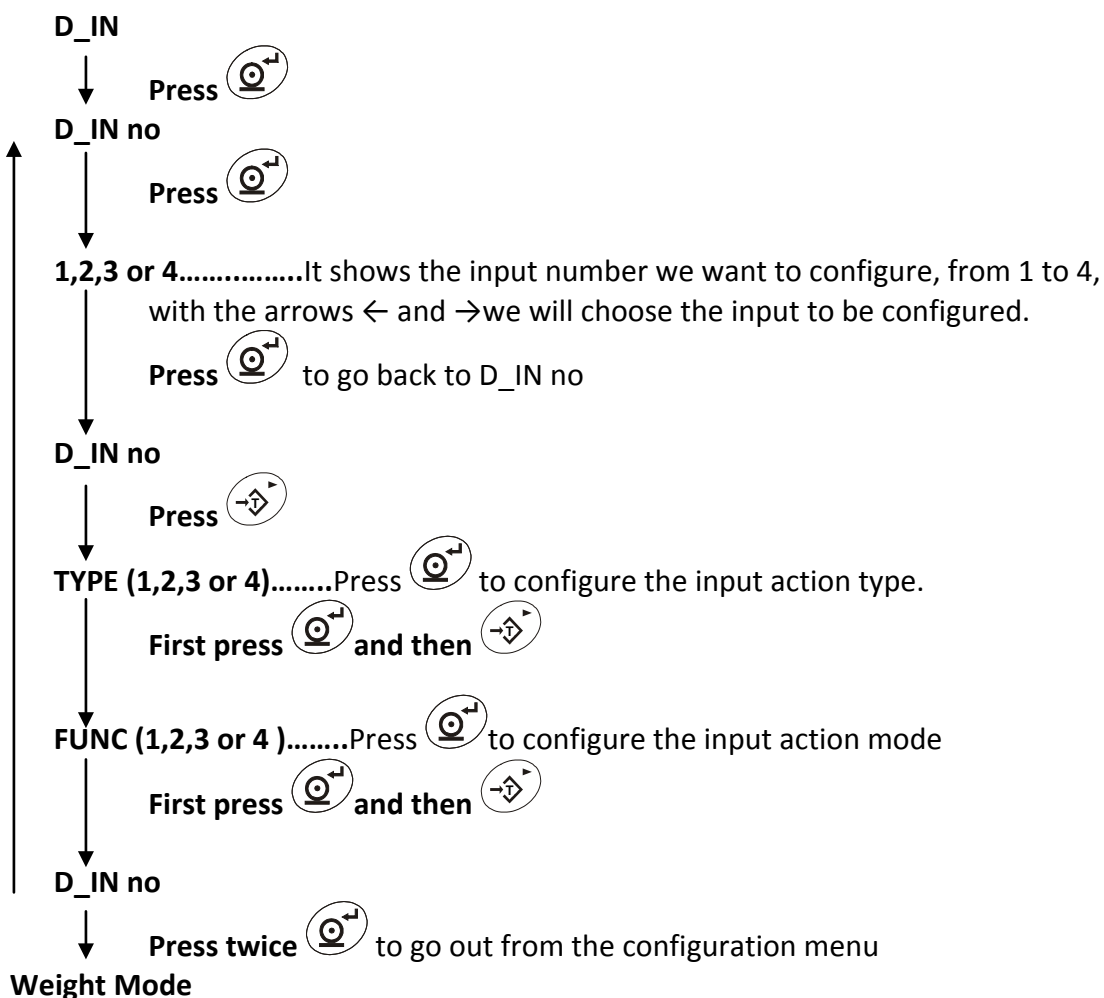

Once are configured the D_OUT and the D_IN, we should perform the following wiring:

The D_OUT 3 will be used to end the maneuver, I mean, we will connect the D_OUT 3 output to the D_IN 2 input, in this way, we will frame the maneuver. When the device will reach the setpoint, it will perform a C.TARE (Clear Tara) automatically to finish the maneuver.

It's shown below the two possible examples of connection, or a SUB-D 25 female connector or a SMART IP-65 (with cable glands).

Multi option wiring connection for digital inputs and outputs with a SUB-D 25 female connector

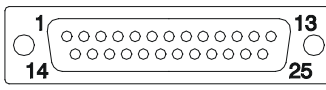
		DIGITAL INPUTS	
		PIN	SIGNAL
 <p>SUB-D 25 aerial female connector Pin allocation welding's side view</p>		5	IN1
		18	IN2
		6	IN3
		19	IN4
		4	GND
		DIGITAL OUPUS	
		PIN	SIGNAL
		9	Vext
		10	D-OUT1
		22	D-OUT2
		11	D-OUT3
		23	D-OUT4
		4	GND

The SUB-D 25 female connector it should be connected as follows:
Pin 11(D_OUT3) with pin 18(IN2) to frame the dosage maneuver.

Wiring diagram for a SMART-IP65 multi option

For a SMART IP-65 the wiring connection of the digital inputs and outputs must be performed as follows.

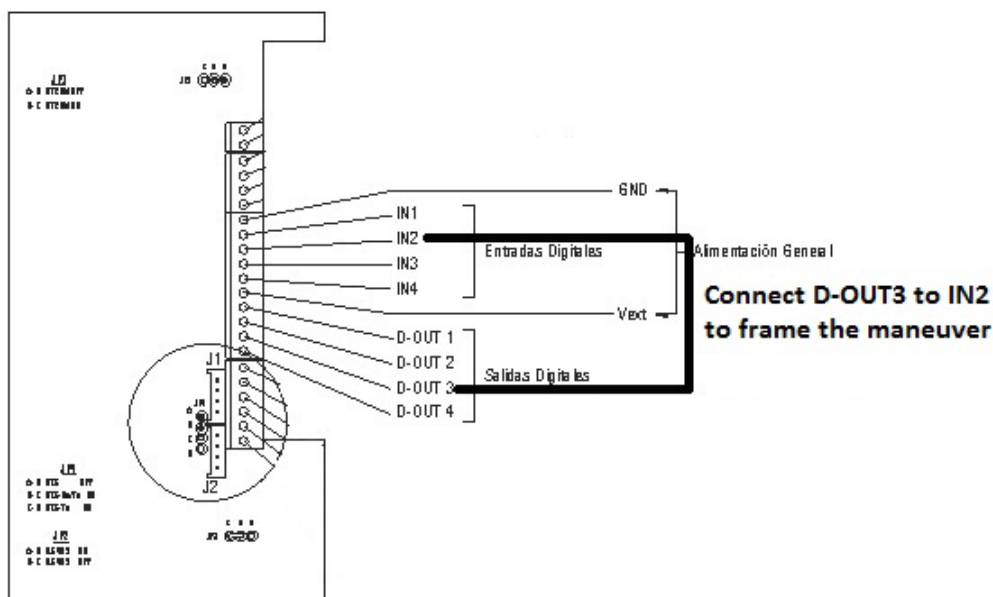

We should perform a bridge between D-OUT3 and IN2 terminal, to frame the dosage maneuver, as shown in the figure.

4 Digital Inputs/4 Relay outputs accessory

Accessory necessary if you want to have 4 digital relay outputs, because with SMART Multi 1 or Multi 2 there are already 4 digital outputs, but these outputs aren't to relay are Open Collector transistors.

